

HOW TO

# IDENTIFY METRIC FITTINGS

## 1. MEASURE THREAD DIAMETER

Use a vernier to measure the thread diameter. Measure the Outer Diameter (OD) for male fittings, and the Inner Diameter (ID) for female.

a Male fitting

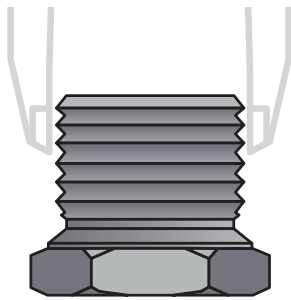

b Female fitting

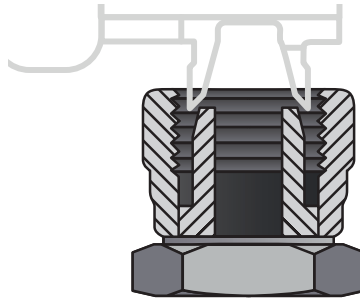

c Tube nut assembly

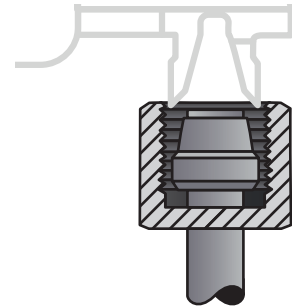

## 2. VERIFY PITCH

With a thread gauge, measure the thread pitch.

i

If you don't have a thread gauge, measure the distance between consecutive thread peaks in mm.

a Male fitting

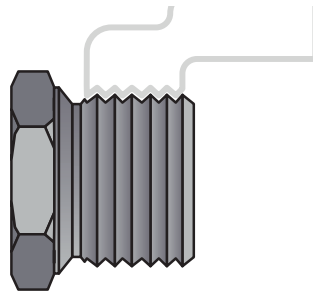

b Female fitting

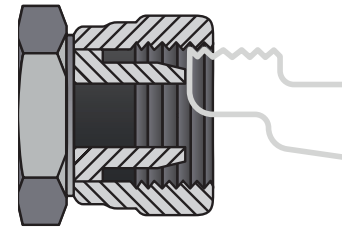

## 3. FEMALES ONLY CALCULATE MALE OD

i

All metric threads are identified by the male measurement. If you only have the female, you can calculate the Male OD using the formula below.

$\text{Thread pitch (mm)} + \text{Female ID (mm)} = \text{Male OD (mm)}$



TAIPAN

sales@taipan.com.au

CONTACT US 1300 654 782  
www.taipan.com.au

# HOW TO IDENTIFY METRIC FITTINGS

## 4. MEASURE TUBE SEAT

Use a vernier to measure the Tube Seat. This measurement is equivalent to the Tube OD.

**i** If you have the tube, simply measure its outer diameter.

**a** Male fitting

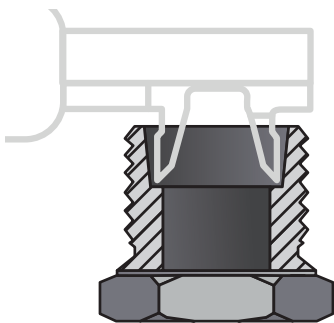

**b** Female fitting

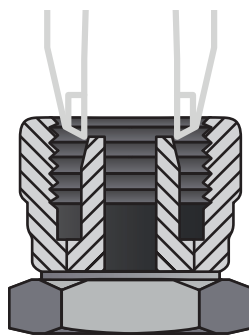

**c** Tube nut assembly

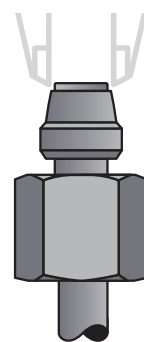

## 5. REFER TO CHART

Example: If Male OD is 12mm and Thread Pitch is 1.5mm then your thread is **M12 x 1.5**.

Use our Metric Thread Identification Chart to match the thread with the Tube OD.

If the case comes up where it could be various options, ensure the cone angle and seat direction match your fitting, using the diagrams as a reference. Inspecting the part, along with any part numbers or markings, can also help determine which series the fitting belongs to.



View or Download the Chart

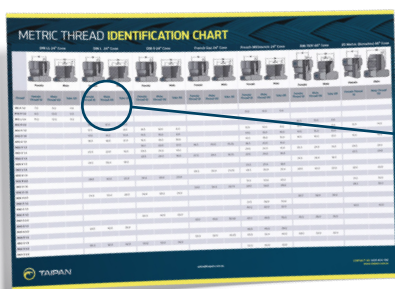

DIN L 24° Cone

Male	Female	Male	Female
Tube OD (mm)	Female Thread ID (mm)	Male Thread OD (mm)	Female Thread ID (mm)
4.0			
6.0			
8.0			
10.5		12.0	6.0
12.5		14.0	8.0

**i**

DIN series fittings will often have a part number referring to the series (LL, L or S). French Gaz & French Millimetric are usually blank.